

DESIGN NOTES

A 1mV Offset, Clock-Tunable, Monolithic 5-Pole Lowpass Filter – Design Note 67

Nello Sevastopoulos

The LTC1063 is the first monolithic lowpass filter simultaneously offering outstanding DC and AC performance. It features internal or external clock tunability, cutoff frequencies up to 50kHz, 1mV typical output DC offset, and a dynamic range in excess of 12 bits for over a decade of input voltage.

The LTC1063 approximates a 5-pole Butterworth lowpass filter. The unique internal architecture of the filter allows outstanding amplitude matching from device to device. Typical matching ranges from 0.01dB at 25% of the filter passband to 0.05dB at 50% of the filter passband. This capability is important for multichannel data-acquisition systems where channel-to-channel matching is critical.

Using the Filter's Internal Oscillator

An internal or external clock programs the filter's cutoff frequency. The clock-to-cutoff frequency ratio is 100:1. In the absence of an external clock, the LTC1063's internal precision oscillator can be used. An external resistor and capacitor set the device's internal clock frequency (Figure 1).

The internal oscillator output is brought out at pin 4 so that it can be used as a synchronized master clock to drive other LTC1063s. Ten or more filters can be locked together to a single LTC1063 clock output as shown in Figure 1.

DC Performance

The LTC1063's output DC offset voltage (typically 1mV or less) is optimized for $\pm 5V$ supply applications. Output offset is low enough to compete with discrete type RC active filters using low offset op amps. Figures 2a and 2b show an LTC1063 filter operating as a clock-sweepable lowpass filter exhibiting no more than 200 μV of total output offset variation over 3 decades of cutoff frequency.

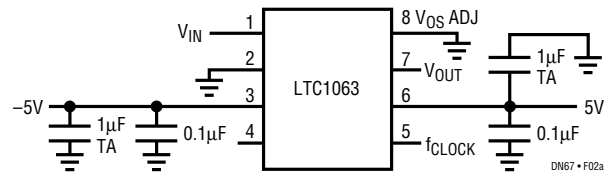

Figure 2a. LTC1063 Operating as a Clock-Sweepable Lowpass Filter

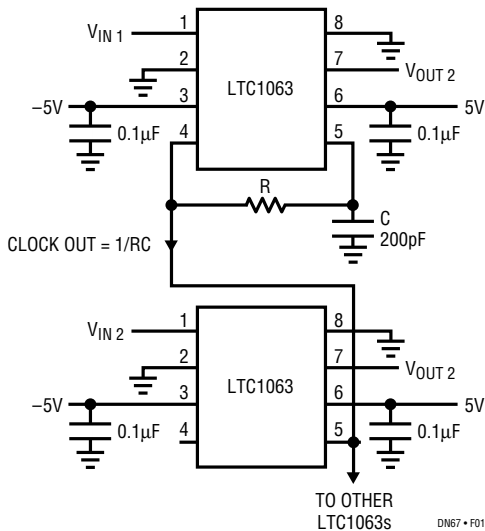

Figure 1. Synchronizing Multiple LTC1063s

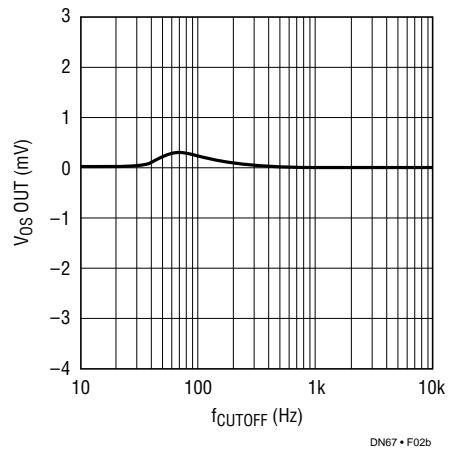

Figure 2b. Output DC Offset vs f_{CUTOFF} for Figure 2a's Circuit

This measurement was taken with a combination of ceramic and tantalum capacitors and a clean PC board layout. DC offset is also affected by input signal DC voltage. The same circuit, Figure 2a, shows a total of 1mV of output offset voltage change with an 8V input change thus, giving a CMRR of 78dB.

Dynamic Range

The LTC1063 has both low noise and very low, $50\mu\text{V}_{\text{RMS}}$, clock feedthrough. The wideband noise is the integral of the noise spectral density; it is usually expressed in μV_{RMS} and is virtually independent of filter cutoff frequency. The LTC1063 has a wideband noise specification of $90\mu\text{V}_{\text{RMS}}$. This number is clock frequency and power supply independent.

The LTC1063's AC design however, is based on optimum dynamic range rather than just wideband noise. Dynamic range measurements take into the account the device's total harmonic distortion. Figure 3a shows the typical connection for dynamic range measurement. An inverting buffer is preferred over a unity-gain follower. Large input common-mode signals can severely degrade the distortion performance of noninverting buffers. It is also important to make sure the undistorted op amp swing is equal to or better than that of the filter. Figure 3b shows the device's operating distortion plus noise versus input signal ampli-

tude measured with a standard 1kHz pure sine wave input. The THD improves with increased power supply voltage.

Figure 3b illustrates how the filter can handle inputs to 4V_{RMS} ($11.2\text{V}_{\text{p-p}}$) with less than 0.02% THD. At this input level, the dynamic range is only limited by distortion and not by wideband noise. The signal-to-noise ratio at 4V_{RMS} input is 93dB. Optimum signal-to-noise plus distortion according to Figure 3b is 83dB, yet a comfortable 80dB (0.01%) is achieved for input levels between 1V_{RMS} and 2.4V_{RMS} .

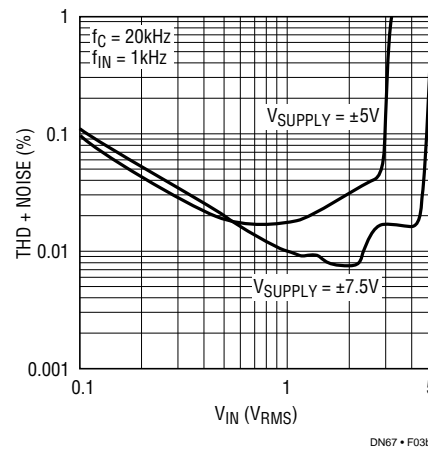

Figure 3b. Plot of Distortion + Noise vs V_{IN}

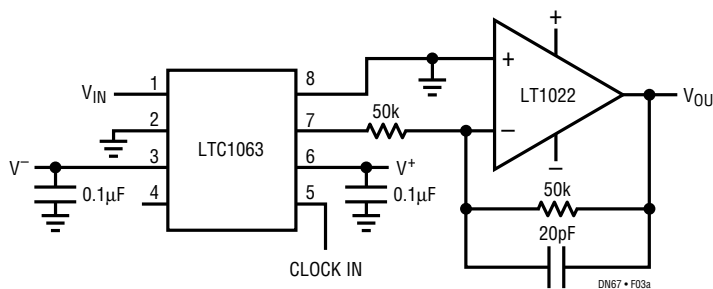

Figure 3a. Typical Connection for Measuring Distortion + Noise and Signal to THD + Noise Ratio

For literature on our Monolithic Filters, call (800) 637-5545. For applications help, call (408) 432-1900, Ext. 456